

ALPA[®]

OF SWITZERLAND

Parallel shift and Scheimpflug lens tilt

The use and ideal design of technical cameras

ALPA Capaul & Weber Ltd.
Neptunstrasse 96
POB 1858
8032 Zürich / Switzerland

Phone: +41 44 383 92 22
Fax: +41 44 382 01 80

Web: www.alpa.ch
Mail: alpa@alpa.ch

Layout: ALPA of Switzerland
Text & Graphics: Walter E. Schön, Munich/Germany
Version: 06.2012

All content © ALPA Capaul & Weber Ltd./Walter E. Schön, 2012

Parallel shift and Scheimpflug lens tilt

The use and ideal design of technical cameras

by Walter E. Schön

Adjustable technical cameras are intended to allow the photographer to correct perspective distortion ("converging lines") when taking shots with a slanted view and to gain more depth of field for the object to be imaged without having to stop down overmuch, that is to avoid diffraction blur.

Such technical cameras therefore offer a **mechanical parallel shift** of the back and/or of the lens to correct perspective distortion and a **mechanical tilting device** of the back and/or of the lens to displace the depth of field in space for a better adaptation to the extent of the motif.

What does "perspective" mean in photography and how is it influenced?

The word "perspective" comes from the Latin *perspicere* = *to look through* and in photography it is used to express how a three-dimensional object is imaged in a plane such that a viewer will still experience a spatial impression.

is located, more precisely the center of the pupil of his viewing eye. The image will appear differently depending on the inclination of the image plane.

To obtain ideal results in this respect, the viewer has to see every point **A'** of the image in the same direction of gaze as he would have seen the corresponding point **A** of the real spatial object from a specific (possibly different) location. The "location" here is the position at which the viewer's eye

If we transfer this principle to a camera, what is decisive for the perspective of the object in the photo is where the center of the lens entry pupil (or aperture) is located and how the image plane is orientated relative to the object (parallel or slanted) and to the direction of gaze (perpendicular or slanted).

This image, which is viewed perpendicular to the image plane, has a correct perspective: Each point of the object is on the same line of vision as the corresponding image point.

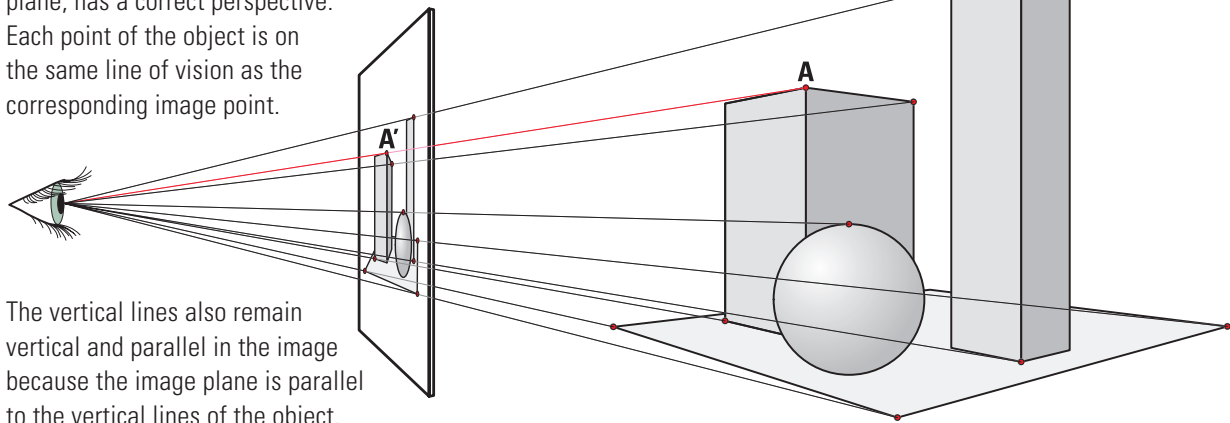

The vertical lines also remain vertical and parallel in the image because the image plane is parallel to the vertical lines of the object.

When viewed as here, this image also has the correct perspective even though the image plane is slightly slanted.

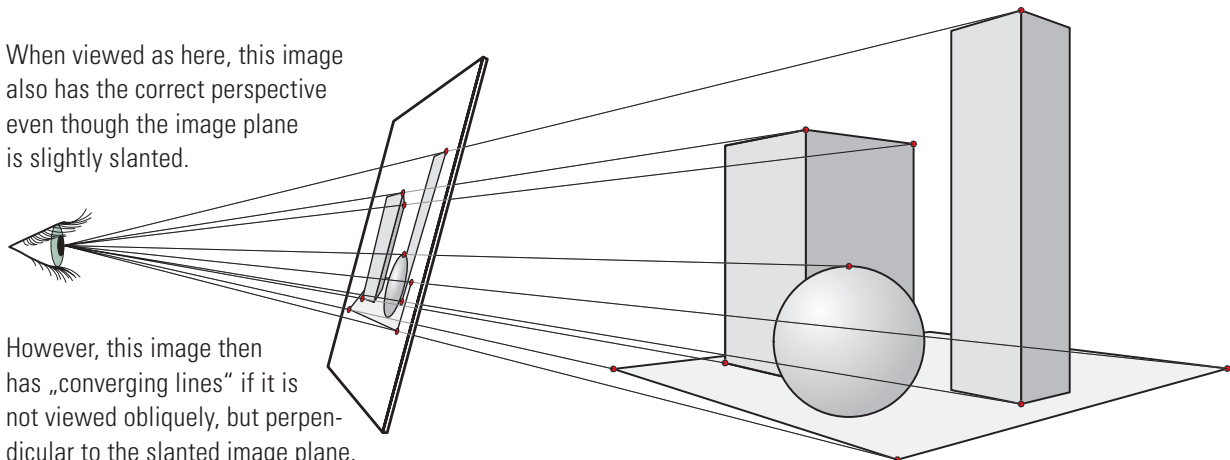

However, this image then has „converging lines“ if it is not viewed obliquely, but perpendicular to the slanted image plane.

How does parallel shift work and why is it needed?

If e.g. a high building is photographed with a camera pointing upward at a slant to get the whole image in the shot, **converging lines** are produced: The vertical edges converge toward the top of the image to a vanishing point; the building narrows at the top and is also compressed vertically (relative to its width).

If the building is photographed so that the **image plane** (= sensor plane or film plane) of the camera is aligned **parallel to these perpendicular edges**, they also remain perpendicular, and so parallel to one another, in the image. With non-adjustable cameras, this is only possible with a horizontal taking direction (= vertical image plane).

In architectural shots, **the upper part of the building is often cut off and too much foreground appears in the image**. To take the whole building with less foreground, a non-adjustable camera has to be held at a slant or the taking location has to be at around half the height of the building instead of close to the ground as with the natural viewpoint of a pedestrian.

Exactly the same problems occur with product shots of objects with perpendicular edges which are usually taken obliquely from above; the only difference is that then the perpendicular edges converge toward the bottom in the image instead of toward the top.

If, however, the camera provides **the possibility of moving the lens or the back up and down**, it is possible to take shots with the camera obliquely from above or below within certain limits (which depend on the maximum movement distance and the angle of view of the lens) **while still keeping the image plane perpendicular**. The corresponding shots show the object **without converging lines**. The ratio between height and width remains correct, that is **with natural proportions**.

In the first instance, it is irrelevant whether **the lens is moved upward or the back downward** for a shot obliquely from below because it is only important that the center of the lens is higher than the center of the image area (of the frame in the back). This also applies in an analogous way (reverse upward and downward) for a taking direction obliquely from above. It is therefore **initially irrelevant whether** the technical camera offers **a parallel shift of the lens or of the back** or even both.

Since **a vertical movement of the lens causes a visible change in the perspective** in close-up shots, it is usually **more favorable to move the back**, at least in the near zone or with a very close foreground. If only the lens can be moved (e.g. with 35 mm cameras with a "shift lens"), it is possible that the entire camera on the tripod will have to be lowered or raised by the vertical movement of the lens for close-up shots after the lens movement to correct the converging lines so that **the lens is in its original position**.

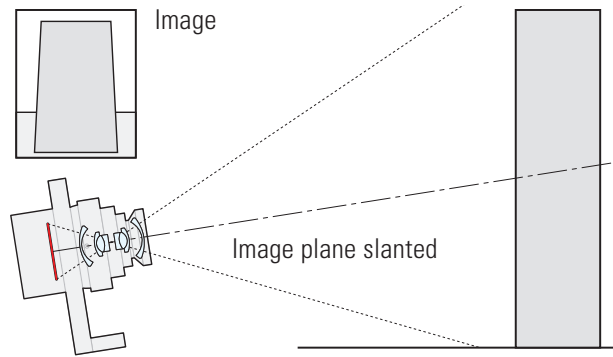

The camera, which is pointed obliquely upwardly, admittedly images the whole building and with only a little foreground, as desired, but does show converging lines.

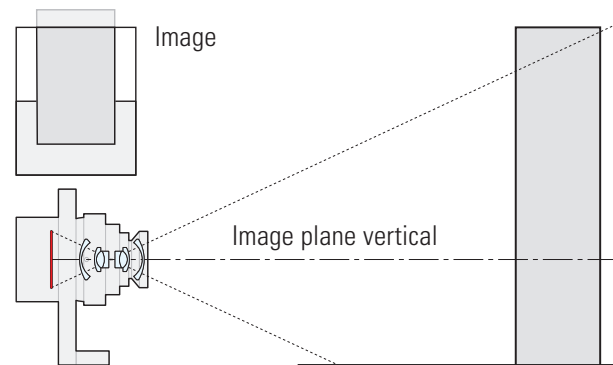

The horizontally aligned camera reproduces the building without distortion at a normal eye level, but not completely and with too much foreground.

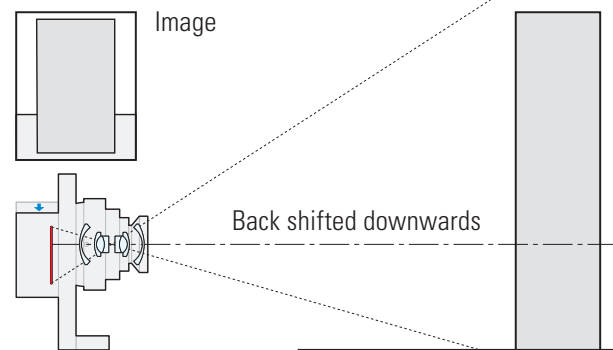

If the back is moved down (upper image) or if the lens is moved up (lower image), a complete image without distortion is possible.

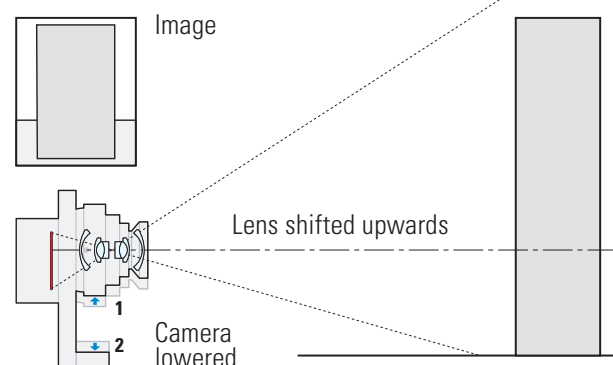

How can the depth of field be utilized better with a Scheimpflug tilt?

Most objects which are photographed are three-dimensional. However, **the lens only provides a sharp image for a certain distance** depending on its focus. The range at either side of the adjustment distance in which the increasing blur is still too small to be disturbingly visible is called the **depth of field**. Its boundaries are defined by **the maximum permitted diameter of the circle of confusion d** which has amounted to **1/1400 of the image diagonal** for around 80 years in analog photography. In a sensor format of 24 mm x 36 mm, this is approx. **0.03 mm**. All standard depth of field scales and tables are based on this.

The better lenses and films have become, the more questionable this value has become because a point image of 0.03 mm diameter is already perceived as blurred relative to the maximum resolution available today when viewing greatly magnified images. The latest high-resolution digital backs and lenses rather require half this value, that is **around 0.015 mm for 35 mm**. It is necessary to **stop down by two more f-numbers** for the same depth of field.

Unfortunately, the **diffraction blur** increases greatly on stopping down (by a factor of 2 for two f-stops). This sets limits on the stepping down: **If you make very high demands on the image definition and so stop down less, you have to accept lower depth of field.**

Theodor **Scheimpflug** proposed one way of escaping this dilemma more than 100 years ago: **It is not possible to gain more depth of field** by tilting the lens or the back, but it can be arranged differently (obliquely) in space and **can so in many cases (but unfortunately not always) be better adapted to the spatial extent of the motif** to be imaged with high definition.

If the image plane **I** and the main lens plane **L** on the image side (we can consider the plane of the diaphragm blades for this purpose) are parallel to one another, the sharply imaged plane **P** and the planes **A** and **B** bounding the depth of field from the front and from the back are also parallel:

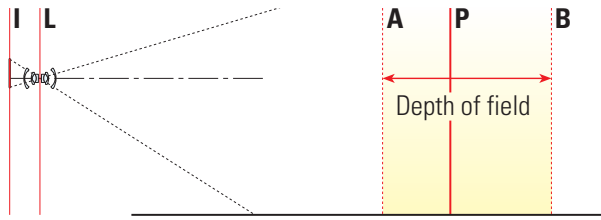

In some technical cameras, the lens can be tilted so that the main lens plane **L** intersects the image plane **I** at the straight line **C** (image below). The sharp plane **P** in the image then likewise extends obliquely through the straight line **C** and the depth of field (yellow zone) previously bounded by parallel planes becomes wedge-shaped. The edge **W** of the wedge is before **C** where the non-tilted lens plane intersects the plane **P**. When the focus is changed, the depth of field wedge rotates about the edge **W** of the wedge: Focusing at a greater distance (image plane **I** is moved from the red to the blue position) tilts the wedge down. Paragraph 7 on page 5 explains how the **Scheimpflug lens tilt** has to be carried out in practice.

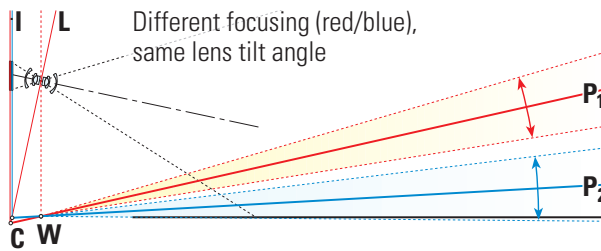

F-number and depth of field (d = circle of diffusion) without Scheimpflug lens tilt

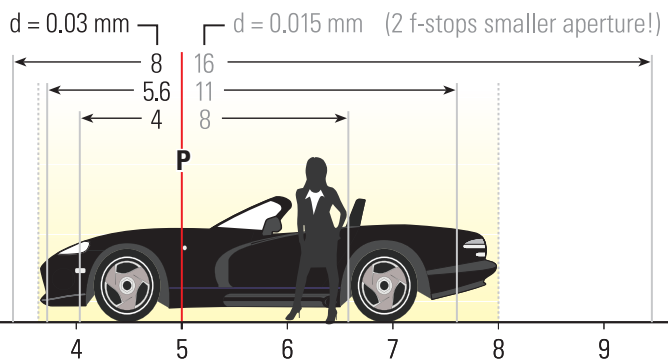
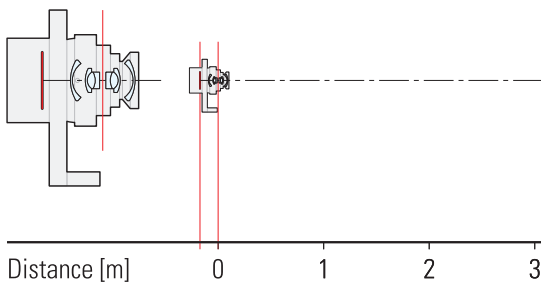

Aperture and depth of field (narrow wedge, but up to infinity) with Scheimpflug lens tilt

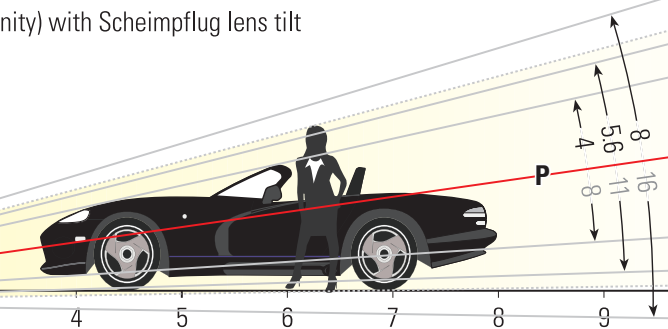
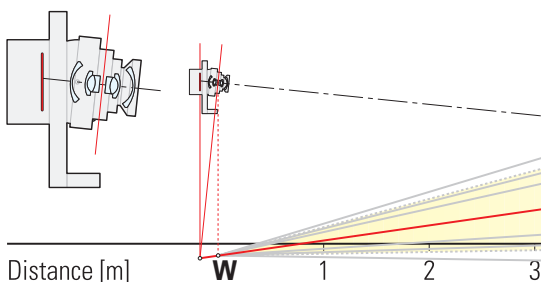

How do I have to focus to ensure the best depth field?

Without a Scheimpflug lens tilt, the image plane **I** and the lens plane **L** are parallel to one another and to the plane **P** in the motif sharp in the image.

It is first impossible to know which plane **P** to focus on and which f-number to step down to in order to get the depth of field over the total motif to be imaged as sharp. The popular rule that the plane **P** lies at the end of the first third between the front boundary **A** and the rear boundary **B** of the depth of field is unfortunately usually incorrect.

There is only one third depth of field in front of and two thirds behind the plane **P** when the rear border **B** is exactly twice as far away as the front border **A**. Otherwise different ratios of almost 1:1 (with macro shots) to 1:∞ (at depth of field up to infinity) result.

As well as being incorrect, the above rule was also rarely practical because it was necessary to know the distance between the front boundary **A** and the rear boundary **B**, to determine the position of the focal plane **P** from this and also to have an object to focus on at this point.

This is the correct focusing method: There are always objects for focusing at the front boundary **A** and at the rear boundary **B** of the depth of field (otherwise the boundaries **A** and **B** would not be exactly there). First **A** is focused on and then **B** or vice versa.

1. With cameras on an optical bench and with focusing by moving the back standard, both focus positions can be marked or read off a scale and noted as numerical values, e.g. 37 and 40. The best focus is **at the center between these two values**; i.e. in this example with 37 and 40, at the scale value 38.5.

2. With cameras with a focusing at the lens, both focus positions can be read off from the distance scale of the lens after the focusing to **A** and to **B**. The correct focus here is also the one **at the center between the two focus positions** (not to the average of the given distance values).

The correct aperture can be located using tables, using a slide rule or using a depth of field scale.

Focusing after a Scheimpflug lens tilt: The depth of field has the shape of a wedge which tilts on focusing onto the edge **W** of the wedge (see figure on page 3). For focusing on **A** and **B**, a respective object point must be taken which contacts these planes (in the bottom figure on page 3 and on page 5 e.g. the head at the top and a shoe of the woman at the bottom) and subsequently **the focus must be at the center between them. The correct aperture can be read off the depth of field scale of focusable lenses** (the distance values there are, however, no longer correct after the Scheimpflug lens tilt and only serve as aids for the respective focus at the near point and at the far point) **or by using a slide rule or using a depth of field scale.**

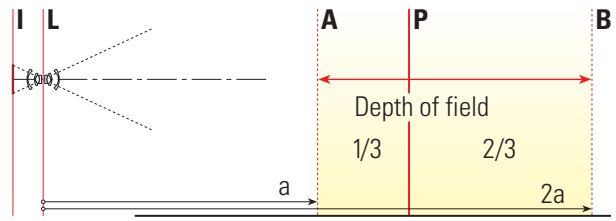

The depth of field is then only 1/3 in front of the focusing plane **P** and 2/3 behind it when the rear depth of field boundary **B** is twice as far away as the front boundary **A**.

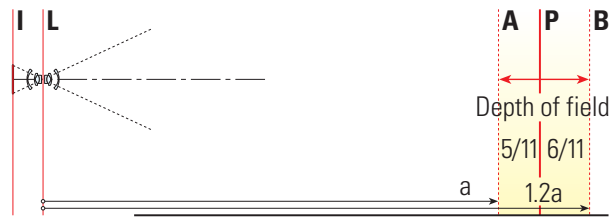

If the depth of field is smaller than the distance **a** from the front depth of field boundary **A**, the depth of field behind the focusing plane **P** is only slightly larger than before it.

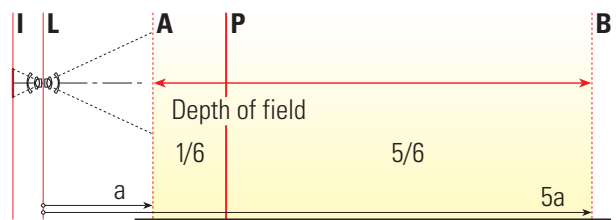

If the depth of field is larger than the distance **a** from the front depth of field boundary **A**, the depth of field behind the focusing plane **P** is much or very much larger than before it.

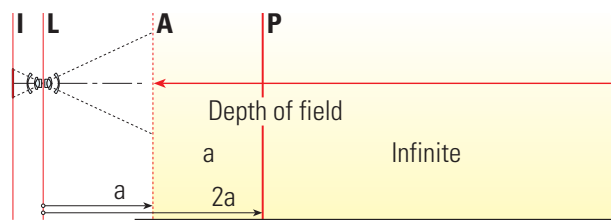

The depth of field then reaches exactly to infinity when the focusing plane **P** is exactly twice as far away (**2a**) as the distance **a** from the front depth of field boundary **A**.

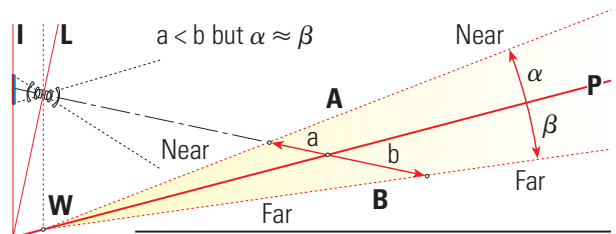

The depth of field **a** before the focusing plane **P** is also always smaller than the depth of field behind the focusing plane **P** after a Scheimpflug lens tilt, with the ratio **a:b** likewise varying. However, the depth of field wedge splits into **two angles of approximately the same values alpha and beta.**

In what order and how are the individual settings to be made?

If converging lines have to be straightened and a Scheimpflug lens tilt becomes necessary as well for “expanded” depth of field, **it is first necessary to correct the distortion and then to carry out the tilt.** The following order of the worksteps allows the fastest and most reliable reaching of the best result:

1. Fixing the ideal camera position

How your motif will appear on the image, which foreground will hide which background, how the size ratio between the foreground and the background will be and many many more aspects depend primarily on the location of the camera.

2. Arrange the objects in wedge shape if possible

If you are setting up the motif yourself (e.g. product shots), try to arrange all the higher objects in the rear so that they lie within an imaginary depth of field wedge to allow a Scheimpflug lens tilt for less stopping down (e.g. for a larger aperture) with minimal diffraction blur.

3. Setting up the camera with a vertical image plane

If “converging lines” need to be avoided, the image plane of the camera must run parallel to the perpendicular edges of the motif even if the taking direction has to run obliquely upwardly or downwardly at the end.

4. Carrying out the parallel shift

Any slanted taking direction which may be required is now established by parallel shift of the back. If the camera (e.g. an SLR camera) only allows a parallel shift of the lens, it may subsequently be necessary for close-ups or with a very close foreground to lower or raise the entire camera accordingly to restore the original lens position and perspective.

5. If desired: Setting the residual perspective

If converging lines should not be completely straightened, but rather some “residual perspective” should remain for a natural effect, the parallel shift initially carried out for the slanted taking direction is reduced by about 1/4 and then the entire camera is tilted so far that the desired picture section is again present. The slight slant which is thus caused generates the residual perspective.

6. Focusing and determining depth of field

If the camera does not allow any Scheimpflug lens tilt or if the motif does not require or permit any Scheimpflug lens tilt, it is now necessary to focus and stop down so that the

depth of field includes the total motif to be imaged as sharp. For this purpose, one respective motif detail has to be defined as the near point **N** in the front plane **A** and as a far point **F** in the rear plane **B** between which everything should be sharp and outside of which blur is permissible.

As we have seen, focusing on the end of the first third between the near point **N** and the far point **F** is incorrect. The correct procedure is to focus on both after one another and then to set the center between both focusing positions. The required aperture is determined from the focus difference (between the focusing positions for **N** and **F**) using a table or a slide rule or read off from the depth of field scale with cameras having a helical focusing facility at the lens.

7. Carrying out the Scheimpflug lens tilt

If the spatial depth of the motif to be imaged as sharp is considerably larger than its height and if you can imagine a depth of field wedge surrounding the whole motif, you can use the Scheimpflug lens tilt. Image (as in the image below) a plane **A'** lying loosely on the motif to be imaged as sharp. It contacts a respective “highest” object **H₁** and **H₂** respectively closer and farther away. Extend the plane **A'** to the intersection line **W'** with the base **B'**. The plane **A'** and the plane **B'** (base) now form our provisional depth of field wedge (which is a little bit different from the final depth of field wedge with **W** below the camera as shown on page 3).

The angle bisector of this wedge indicates how the focusing plane **P** should run. Since you do not know the angle by which the lens has to be tilted for this purpose, simply tilt it by a small estimated angle, e.g. by 2°. Focus on the detail **X** in the plane **P** near the front in the motif at half the height of **H₁**. Then check where **H₂** is the sharpest: If that is also at half the height **Y**, you have completed the tilting. If the best sharpness is higher, increase the tilt angle, e.g. to 3°. If it is lower, reduce the angle, e.g. to 1.5° or 1°. Refocus on **X** and check the sharpness again at **H₂**. Repeat until you have the best sharpness in each case at half the height at **H₁** and **H₂**.

8. Final focusing after the tilting

Focus to the sharpness as described under point 6 but so that the near point **N** is the highest point of **H₂** in the plane **A'** and the far point **F** is a point at the bottom in the plane **B'**. Please follow the instructions at the bottom of the left text column of page 4

How to find the lens tilt angle and how to focus for best depth of field

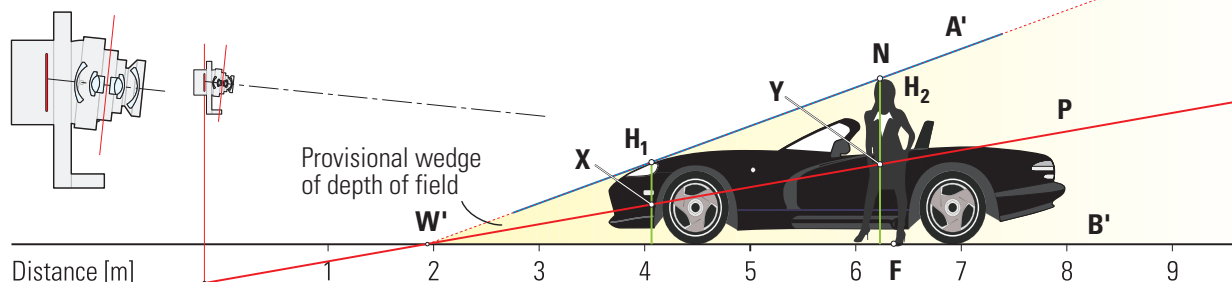

Parallel shift and Scheimpflug lens tilt with technical cameras

We are looking for a technical camera with which converging lines can be corrected and where the depth of field can be adapted to the motif extent by a Scheimpflug lens tilt. Such a camera must offer devices for the parallel shift or tilting of either the back or of the lens or of both. Which design solution is the best for practice?

The parallel shift is intended to shift the image section transversely to the taking direction so that a slanted taking direction results without tilting the image plane. Generally, this is possible with the back or the lens. So that the image sharpness is not changed, the back or the lens has to be shifted parallel to the image plane.

The back shift is better because the position of the lens does not change, that is there is no vertical offset between the foreground and the background in the near zone which may require a subsequent vertical change of the camera (by a column shift at the tripod) for retaining the perspective.

The Scheimpflug tilt by a tilting of the lens plane **L** toward the image plane **I** (in the back), or vice versa, should form the depth of field otherwise bounded by two parallel planes into a slanted wedge shape which can be better adapted to the shape and extent of the motif.

The lens tilt is better because the image plane aligned perpendicular (or almost perpendicular in the case of the residual perspective) for the correction of converging lines remains unchanged. A further advantage is that on a subsequent correction of the image framing after the lens tilt, a further parallel shift does not change the image sharpness because the image remains in the same plane.

If the back has to be tilted because the camera does not allow a lens tilt for design reasons, the image plane aligned perpendicular (or almost perpendicular for residual perspective) initially to avoid converging lines is moved to a slanted position: Converging lines would again appear - even in the false direction with shots obliquely from above! For this reason, the camera has to be tilted using the tilting head of the tripod after the back tilt so that the image plane is again perpendicular (or almost perpendicular).

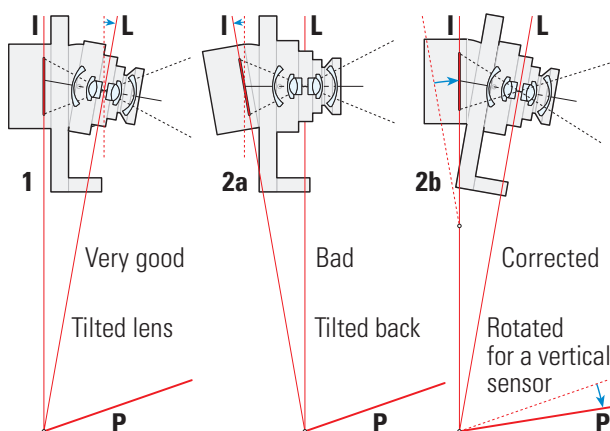

However, the tilt of the camera causes the plane **P** previously adapted to the motif by the tilting of the back to tilt by the same angle (blue arrows). Only a subsequent focusing to a shorter distance (= larger distance between the image plane and the lens, see second image on page 3) allows the plane **P** again to pivot back into the dotted starting position.

The back shift and the lens tilt are therefore generally the best conditions for **simple, fast working without subsequent correction** of the picture detail, image sharpness and camera position. The principle of a good technical camera is then as follows:

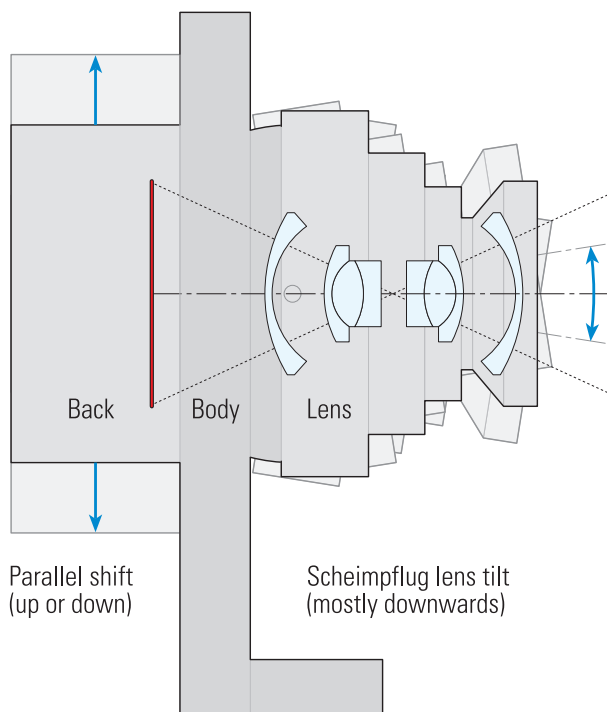

A further solution would be the **parallel shift and tilt possibility at the front at the lens** (as with shift lenses of 35 mm SLR cameras). In this case, the parallel shift should be on the camera side and the pivot possibility in front of it because a further parallel shift taking place after the lens tilt to recompose the subject within the frame will only then not change the image sharpness.

If the tilt range of the lens is strictly limited due to a lack of space, e.g. to 4°, a **wedge-shaped intermediate piece** with a wedge angle (as large as the maximum tilt angle) could be inserted between the camera housing and the lens or between the camera housing and the back **which doubles the pivot range**. If it can only be inserted between the housing and the back, the camera must thus be aligned before all other camera adjustments to avoid converging lines so that the picture plane is perpendicular. However, then (as already described for the back tilting), the sharpness will change and refocusing will become necessary on any subsequent parallel shift which may become necessary if you want to recompose the subject. ■

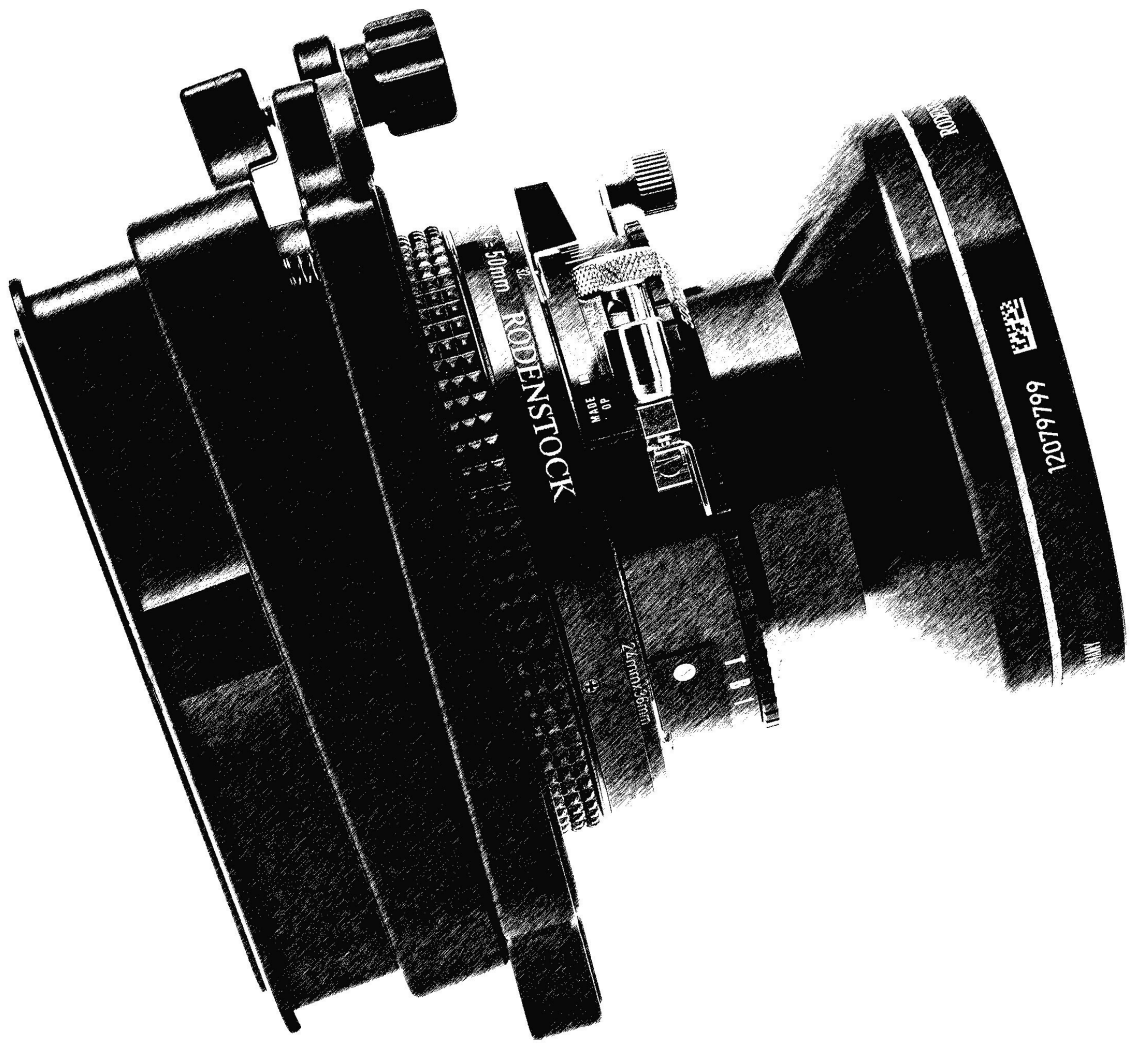

RODENSTOCK

50mm

1:1.8

Zeiss Ikon

12079799

100%

